

## VB Series (Bellows)

### Features and Strengths

Particularly good for use on curved surfaces and for separating thin sheets of materials in stacks.

The bellows cup is very good at compensating for a degree of difference in level and curvature of the work piece, more angular and level compensation can be achieved by using other **Vtec** cup accessories.



### Suitable for Handling

- Sheet Veneer
- Plastic Sheets
- Paper Box handling
- Thin Film Sheets
- Cardboard Boxes and Electronic Components

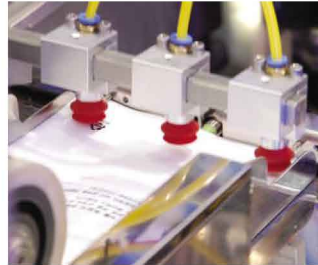

### Order No.

**VB30 PU F - 18F EV - L1820T - BJ 18**

①                    ②                    ③                    ④                    ⑤                    ⑥                    ⑦

► See pages 21, 60-67.

#### ① Diameter

VB5	- Ø5
VB6X	- Ø6
VB8	- Ø8
VB10	- Ø10
VB12	- Ø12
VB15	- Ø15
VB17	- Ø17
VB20	- Ø20
• <b>VB30</b>	- Ø30
VB40	- Ø40
VB50	- Ø50
VB75	- Ø75
VB75B	- Ø75
VB110	- Ø110
VB110B	- Ø110
VB150	- Ø150

#### ② Material

N	- NBR
S	- Silicon
WS	- White Silicon
HS	- High Temp. Silicon
CS	- Conductive (Special mat'l)
U	- Urethane
A	- Mark Free
• <b>PU</b>	- Poly Urethane*
WPU	- Poly Urethane* (Minimal mark)

\*Only for VB15, VB20, VB30, VB40, VB50, VB75

#### ③ Filter

no mark	- Standard
• <b>F</b>	- With filter (PE) VB30, VB40, VB50, VB75, VB110

#### ④ Thread size

M5M	- M5 male (VB5, VB8, VB10, VB12, VB15)
18M	- G1/8" male (VB30, VB40)
14M	- G1/4" male (VB30, VB40, VB50)
38M	- G3/8" male (VB50)
M518MF	- M5 female and G1/8" male (VB17, VB20)
M518MFB*	- M5 female and G1/8" male (VB20)
• <b>18F(A)</b>	- G1/8" female (VB17, VB20, VB30, VB40, VB50, VB75, VB75B)
18FB*	- G1/8" female (VB30, VB40)
14F(A)	- G1/4" female (VB75, VB75B)
38F(A)	- G3/8" female (VB75, VB75B)
12F(A)	- G1/2" female (VB75, VB75B, VB110, VB110B, VB150)
M5X5F	- M5X5 female (VB17, VB20)
18X5F	- G1/8" X 5 female (VB30, VB40, VB50)

Remark : VB30~150 fittings are including mesh filter.

\* Only for silicon material

(A) : AL-Material (Only VB75, VB75B)

#### ⑤ Valves Efficiency valve : EV

no mark	- standard
• <b>EV</b>	- Vacuum efficiency valve (See page : 16) (VB17, VB20, VB30, VB40, VB50)

## Accessories order No.

### L1820T      BJ 18

⑥

⑦

⑥ Level compensator		⑦ Ball joint model
Model	Stroke (mm)	
L506TX, L506TS, L506TM, L506TU	6	• BJ 18
L510LTX, L510LTS, L510LTM, L510LTU	10	
L507T, L507TN	7	
L515T	15	
L510, L510T	10	
L520, L520T, L520TF	20	
L1805F	5	
L525TXN, L525TSN, L525TMN, L525TUN	25	
L1805M, L1805F	5	
L1810T, L1810TS, L1810TSE	10	
L1815T, L1815	15	
• L1820T, L1820TS	20	
L1820TN*	20	
L1830, L1830T, L1830TS	30	
L1850, L1850T	50	
L1230, L1230T	30	BJ 12
L1250, L1250T	50	

\*Not available with Ball Joint (BJ).

SUCTION  
CUPS

## Recommended (max.) lifting forces

Model	Volume (cm <sup>3</sup> )	Lifting Force (kg) – Parallel 		
		-20 kPa	-60 kPa	-90 kPa
VB5	0,05	0,03	0,08	0,10
VB6X	0,09	0,05	0,11	0,14
VB8	0,15	0,08	0,16	0,25
VB10	0,48	0,15	0,34	0,5
VB12	0,59	0,2	0,41	0,62
VB15	1,1	0,29	0,6	0,9
VB17	1,5	0,4	0,8	1
VB20	2,7	0,6	1	1,42
VB30	10	1,22	2,24	2,75
VB40	15	2,24	3,97	5
VB50	32	3,36	6,63	8,36
VB75(B)	110	7,65	17,04	23,06
VB110(B)	310	13,97	35	47,04
VB150	650	30	70	90,1

## Dimensional information

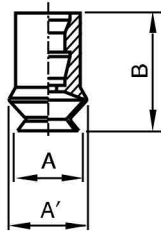

◀ VB6X [mm]

Model	A	A'	B
VB6X	7	9	13.5

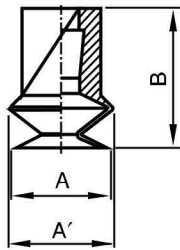

◀ VB5 VB8 VB10 VB12 VB15 [mm]

Model	A	A'	B
VB5	5.8	6.2	9.2
VB8	8.8	9.6	11.9
VB10	11	12	16
VB12	12	14	16.5
VB15	15.5	17.5	19.5

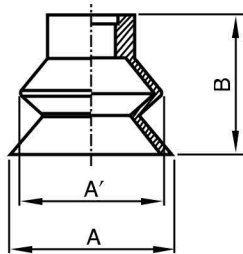

◀ VB17 [mm]

Model	A	A'	B
VB17	18.5	16.6	15.6

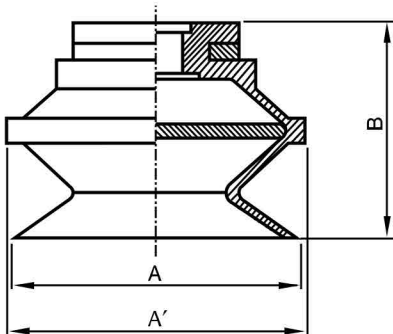

◀ VB20 VB30 VB40 VB50 [mm]

Model	A	A'	B
VB20	22	24	19
VB30	34	36	26
VB40	43	46	28
VB50	53	58	35

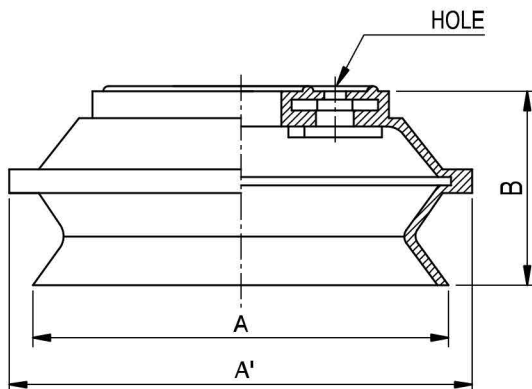

◀ VB75 VB110 VB150 [mm]

Model	A	A'	B	HOLE
VB75(B)	78	83	37	4- $\phi$ 6.5 P.C.D $\phi$ 35
VB110(B)	115	124	54	8- $\phi$ 6 P.C.D $\phi$ 55
VB150	155	166	71	8- $\phi$ 6 P.C.D $\phi$ 70.5

## Dimensional information

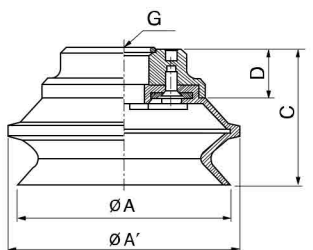
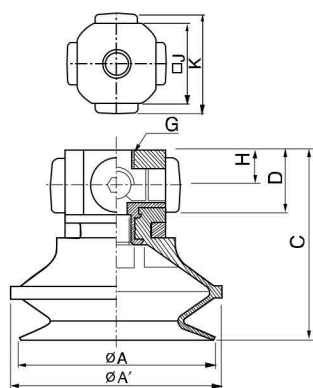
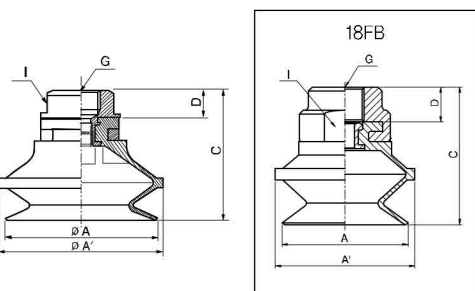
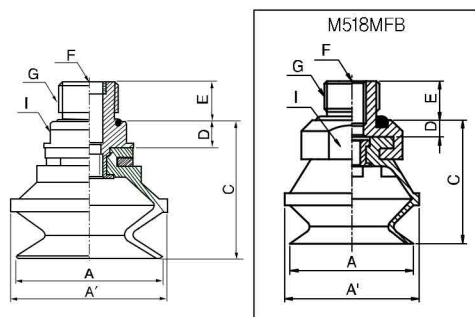
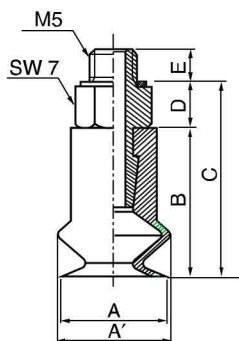

### ◀ Male thread

[mm]

Model	ØA	ØA'	B	C	D	E
VB5-M5M	5,6	6,2	9,2	13,2	4	3,5
VB8-M5M	8,8	9,6	11,9	15,9	4	3,5
VB10-M5M	11	12	16	21	5	4
VB12-M5M	12	14	16,5	21,5	5	4
VB15-M5M	15,5	17,5	19,5	24,5	5	4

### ◀ Male thread

[mm]

Model	ØA	ØA'	C	D	E	F	G	I
VB17-M518MF	18,5	16,6	17,1	1,5	6	M5	G1/8"	SW12
VB20-M518MF	22	24	20,5	1,5	6	M5	G1/8"	SW12
VB20-M518MFB*	22	24	22	3	7	M5	G1/8"	SW16
VB30-18M	34	36	31	5	7	-	G1/8"	SW17
VB30-14M	34	36	32	6	9	-	G1/4"	SW17
VB40-18M	43	46	33	5	7	-	G1/8"	SW17
VB40-14M	43	46	34	6	9	-	G1/4"	SW17
VB50-14M	53	58	41	6	9	-	G1/4"	SW24
VB50-38M	53	58	41	6	10	-	G3/8"	SW24

\*Only for silicon material

### ◀ Female thread

[mm]

Model	ØA	ØA'	C	D	G	I
VB17-18F	18,5	16,6	23,6	8	G1/8"	SW15
VB20-18F	22	24	27	8	G1/8"	SW15
VB30-18F	34	36	34	8	G1/8"	SW17
VB30-18FB*	34	36	35	9	G1/8"	SW21
VB40-18F	43	46	36	8	G1/8"	SW17
VB40-18FB*	43	46	37	9	G1/8"	SW21
VB50-18F	53	58	44	9	G1/8"	SW24

\*Only for silicon material

### ◀ Female threadx5

[mm]

Model	ØA	ØA'	C	D	G	H	□J	K
VB17-M5X5F	18,5	16,6	24,6	9	M5X5	5	15	22
VB20-M5X5F	22	24	28	9	M5X5	5	15	22
VB30-18X5F	34	36	44	18	G1/8"X5	10	22	30
VB40-18X5F	43	46	46	18	G1/8"X5	10	22	30
VB50-18X5F	53	58	53	18	G1/8"X5	10	28	36

### ◀ Female thread

[mm]

Model	ØA	ØA'	C	D	G
VB75(B)-18F	78	83	50	18	G1/8"
VB75(B)-14F	78	83	50	18	G1/4"
VB75(B)-38F	78	83	50	18	G3/8"
VB75(B)-12F	78	83	50	18	G1/2"
VB110(B)-12F	115	124	63	15	G1/2"
VB150-12F	155	166	78	14	G1/2"